



**Jazzy**  
**air**<sup>®</sup> SERIES

Included Models:  
Jazzy Air<sup>®</sup> 2 and Jazzy Air<sup>®</sup> MED

# SAFETY GUIDELINES



**WARNING!** An authorized Pride Provider or a qualified technician must perform the initial setup of this power chair and must perform all of the procedures in this manual.

The symbols below are used throughout this owner's manual and on the power chair to identify warnings and important information. It is very important for you to read them and understand them completely.



**WARNING!** Indicates a potentially hazardous condition/situation. Failure to follow designated procedures can cause either personal injury, component damage, or malfunction. On the product, this icon is represented as a black symbol on a yellow triangle with a black border.



**MANDATORY!** These actions should be performed as specified. Failure to perform mandatory actions can cause personal injury and/or equipment damage. On the product, this icon is represented as a white symbol on a blue dot with a white border.



**PROHIBITED!** These actions are prohibited. These actions should not be performed at any time or in any circumstances. Performing a prohibited action can cause personal injury and/or equipment damage. On the product, this icon is represented as a black symbol with a red circle and red slash.

## INTENDED USE

The intended use of this Pride Mobility Products device is to provide mobility assistance to persons with mobility impairment who have the capacity to operate a motorized mobility power chair in an indoor/outdoor environment.

## Regarding Devices for Prescription Use

Our mobility products and their and components are available for sale either as retail ("over-the-counter") or with a prescription. When prescribed, the follow statement is applicable.



**CAUTION!** Federal law restricts this device to sale by or on the order of a physician or other certified personnel licensed by the law of the State (US only) or region in which this personnel practices to use or order the use of the device.

## Quick Reference Information

Authorized Pride Provider: \_\_\_\_\_

Address: \_\_\_\_\_

Telephone: \_\_\_\_\_

Purchase Date: \_\_\_\_\_

*NOTE: This owner's manual is compiled from the latest specifications and product information available at the time of publication. We reserve the right to make changes as they become necessary. Any changes to our products may cause slight variations between the illustrations and explanations in this manual and the product you have purchased. The latest/current version of this manual is available on our website.*

*NOTE: This product is compliant with WEEE, RoHS, and REACH directives and requirements.*

*NOTE: This product meets IPX4 classification (IEC 60529).*

*NOTE: This product and its components are not made with natural rubber latex. Consult with the manufacturer regarding any after-market accessories.*

# CONTENTS

<b>I. INTRODUCTION</b>	4
<b>II. SAFETY</b>	5
<b>III. YOUR POWER CHAIR</b>	7
<b>IV. ASSEMBLY</b>	15
<b>V. COMFORT ADJUSTMENTS</b>	17
<b>VI. BATTERIES AND CHARGING</b>	21
<b>VII. CARE AND MAINTENANCE</b>	25

**ADVISORY STATEMENT REGARDING CERTAIN COMPONENTRY INCORPORATED BY THIRDPARTY MANUFACTURERS INTO FINISHED POWER CHAIRS:** When Pride power bases, seating systems, or other components are incorporated into a finished power chair manufactured or assembled by any third party, that third party is responsible to assure the safety, functionality, and legal compliance of the finished power chair. Pride makes no representation concerning the safety, functionality, or legal compliance of the finished power chair or its componentry manufactured by a third party. While Pride makes every effort to assure that our components are distributed responsibly, manufacturers, distributors, and consumers are reminded that finished power chairs must comply with a variety of standards and requirements for governmental safety and functionality.

If it is necessary to physically modify a power chair, including the addition of third-party componentry, to accommodate the medical needs of the power chair occupant, a risk assessment in conformance with ISO 14971, as outlined in ISO 7176, should be performed.

Changes to power chairs that are likely to affect conformance and risk evaluation include but are not limited to: moving the securement-point brackets; lowering the back-support height; shortening the seat length; adding secondary postural supports that are not firmly attached to the power chair; adding components that have sharp edges (i.e., edges with less than 0.08 in. [2 mm] radius); or any change that compromises the structural integrity of the power chair frame.

## LANGUAGE USAGE

This owner's manual is intended for distribution in all English-speaking countries where our Power Chairs are sold. We have chosen to compose this manual using language and spellings common to the USA. Since we recognize that not all English-speaking countries use the same words or spellings, please refer to the following chart for some common word variations that may be encountered throughout this manual.

USA	Variation	USA	Variation	USA	Variation
asphalt	tarmac	backward(s)	rearward(s)	center	centre
color	colour	cord	lead	curb	kerb
elevator	lift	meter	metre	provider	dealer; agent
sidewalk	pavement	tire	tyre	trunk	boot
turn signal	turn indicator	yard	grounds	wrench	spanner
caster	castor	pocketbook	handbag	counterclockwise	anticlockwise
authorized	authorised	path	footpath	path	bridleway
labor	labour				

# I. INTRODUCTION

## **SAFETY**

WELCOME to Pride Mobility Products (Pride). The power chair you have purchased combines state-of-the-art components with **safety**, comfort, and styling in mind. We are confident that these design features will provide you with the conveniences you expect during your daily activities. Once you understand how to **safely** operate and care for your power chair, it should give you years of trouble-free operation and service.

**Read and follow** all instructions, warnings, and notes in this manual before attempting to operate your power chair for the first time. You must also read all instructions, warnings, and notes contained in any supplemental instructional booklets for the controller, front riggings, and/or seating system that accompanied your power chair before initial operation. Your **safety** depends upon you, as well as your provider, caretaker, or healthcare professional, in using good judgment.

If there is any information in this manual which you do not understand, or if you require additional assistance for setup or operation, please contact your authorized Pride Provider. **Failure to follow the instructions in this manual and those located on your power chair can lead to personal injury and/or damage to the power chair, and may void the warranty.**

## **PURCHASER'S AGREEMENT**

By accepting delivery of this product, you promise that you will not change, alter, or modify this product or remove or render inoperable or unsafe any guards, shields, or other safety features of this product; fail, refuse, or neglect to install any retrofit kits from time to time provided by Pride to enhance or preserve the safe use of this product.

## **SHIPPING AND DELIVERY**

Before using your power chair, make sure your delivery is complete as some components may be individually packaged. If you do not receive a complete delivery, please contact your authorized Pride Provider immediately. Where damage has occurred during transport, either to the packaging or content, please contact the delivery company responsible.

***NOTE:** If you ever lose or misplace your copy of this manual, contact us and we will be glad to send you a new one immediately.*

# II. SAFETY

## PRODUCT SAFETY SYMBOLS

The symbols below are used on the power chair to identify warnings, mandatory actions, and prohibited actions. It is very important for you to read and understand them completely.

*NOTE: There are more warnings identified and explained in the Consumer Safety Guide that is included with your power chair. Please become familiar with all the warnings and safety information found in the Consumer Safety Guide and refer to this resource often.*



**Read and follow the information in the owner's manual.**



**Locked and in drive mode.**

**Place unit on level ground and stand to one side when changing from drive mode to freewheel mode or freewheel mode to drive mode.**

**Unlocked and in freewheel mode.**



OR



**Indicates power chair securement points.**



OR



**Power chair not rated for occupied transit.**

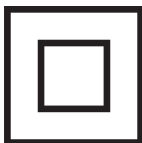

**Class II equipment**



OR



**Manufactured in**



**Power chair information label**

# II. SAFETY

## GENERAL GUIDELINES



**MANDATORY! Do not operate your new power chair for the first time without completely reading and understanding this owner's manual.**

Your power chair is a state-of-the-art life-enhancement device designed to increase mobility. Pride provides an extensive variety of products to best fit the individual needs of the power chair user. Please be aware that the final selection and purchasing decision regarding the type of power chair to be used is the responsibility of the power chair user, who is capable of making such a decision, and his/her healthcare professional (i.e., medical doctor, physical therapist, etc.).

The contents of this manual are based on the expectation that a mobility device expert has properly fitted the power chair to the user and has assisted the prescribing healthcare professional and/or the authorized Pride Provider in the instruction process for the use of the product.

There are certain situations, including some medical conditions, where the power chair user will need to practice operating the power chair in the presence of a trained attendant. A trained attendant can be defined as a family member or care professional specially trained in assisting a power chair user in various daily living activities.

As you begin using your power chair during daily activities, you will probably encounter situations in which you will need some practice. Simply take your time and you will soon be in full and confident control as you maneuver through doorways, on and off of elevators, up and down ramps, and over moderate terrain.

Below are some precautions, tips, and other safety considerations that will help you become accustomed to operating your power chair safely.

### Pre-Ride Safety Check

Get to know the feel of your power chair and its capabilities. Pride recommends that you perform a safety check before each use to make sure your power chair operates smoothly and safely.

#### Perform the following inspections prior to using your power chair:

- Check for proper tire inflation. Maintain but do not exceed the psi/bar/kPa air pressure rating indicated on each tire if equipped with pneumatic tires.
- Check all electrical connections. Make sure they are tight and not corroded.
- Check all controller connections to the power base. Make sure they are secured properly.
- Check the brakes. See VII. "Care and Maintenance."
- Check battery charge. See VI. "Batteries and Charging."
- Ensure the manual freewheel levers are in drive mode before sitting on the power chair.

**NOTE: If you discover a problem, contact your authorized Pride Provider for assistance.**



**WARNING! In the event of a loss of power to the power chair, transfer to a safe position, seeking assistance if needed. Contact your authorized Pride Provider immediately to report the incident. Failure to transfer to a safe position may result in personal and/or property damage.**

### Mode of Operation

Actuator Maximum Duty Cycle: 6 min. ON/54 min. OFF

**NOTE: To extend the life of the actuator, Pride recommends not using the actuator function repeatedly for an extended period of time, not to exceed 12 times per hour, on average. We recommend that you closely review the instructions, specifications, and safety information set forth by the manufacturer of the lift elevation product before using that product. Refer to <https://www.reac-group.com> for more information.**

# III. YOUR POWER CHAIR

## THE JAZZY AIR® SERIES POWER CHAIR

The Jazzy Air® Series Power Chair has two main assemblies: the seat assembly (A) and the power base assembly (B). See figure 1. Typically, the seat assembly includes the armrests, seatback, and seat base. The power base assembly includes two motor/brake assemblies, two drive wheels, four caster wheels, two batteries, and wiring harnesses. See figures 1, 2, and 3.

### Identification Key

- |                                      |  |
|--------------------------------------|--|
| 1. Seatback                          | 8. Body Shroud                         |
| 2. Armrest                           | 9. Front Rigging (Foot Platform Shown) |
| 3. Lift Mechanism Switch*            | 10. Rear Caster Wheel                  |
| 4. Controller                        | 11. Drive Wheel                        |
| 5. Seat Base                         | 12. Marker Lights*                     |
| 6. Light Switch (for Marker Lights)* | 13. Front Caster Wheels                |
| 7. Under Seat Storage*               |  |

*\*Jazzy Air® 2 only*

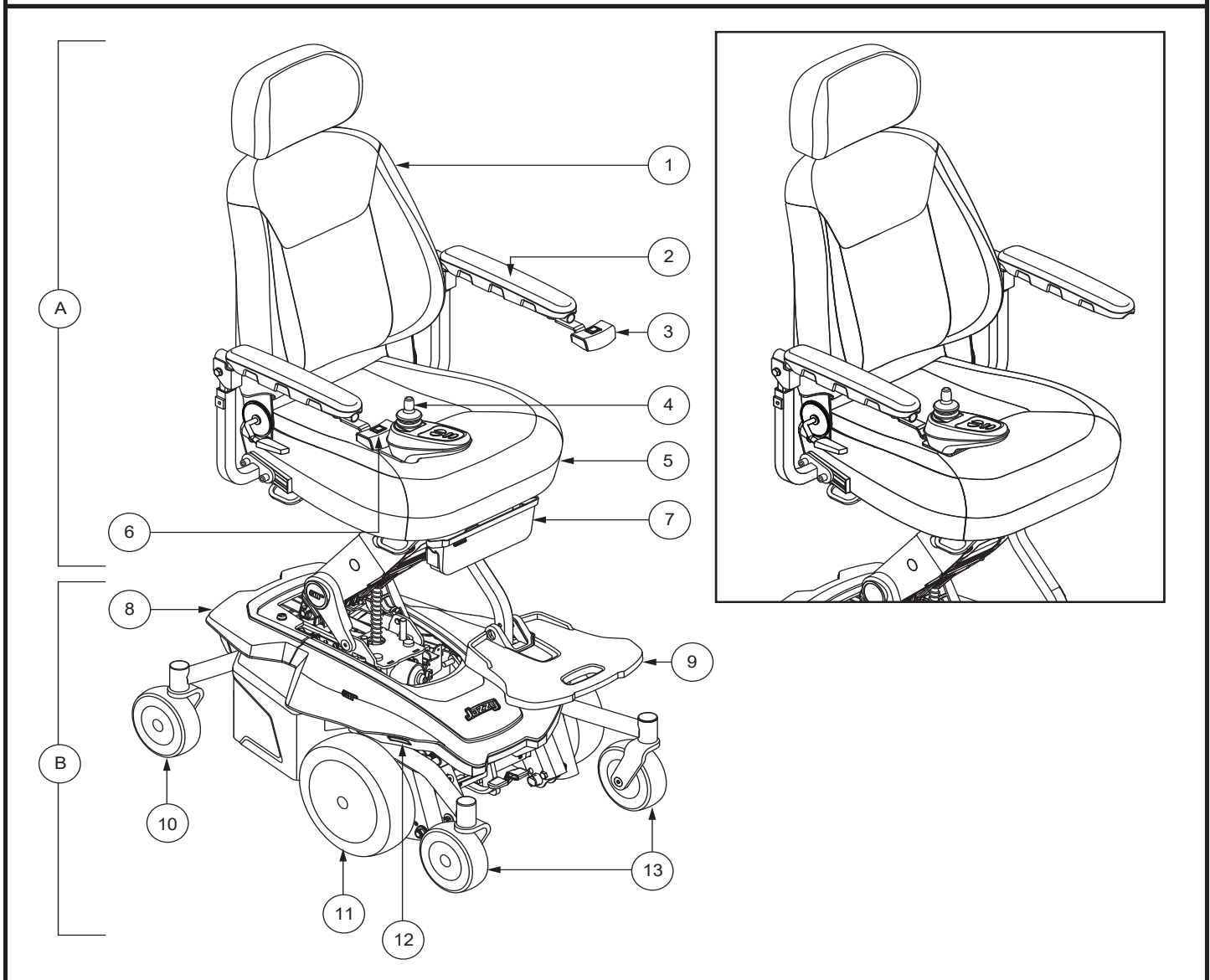
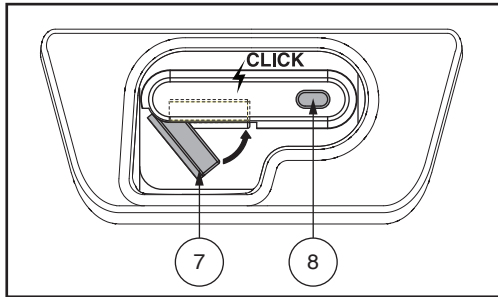

Figure 1. The Jazzy Air® 2 and Jazzy Air® MED Power Chairs

# III. YOUR POWER CHAIR

## Identification Key

- |                         |                           |
|-------------------------|---------------------------|
| 1. Lifting Mechanism    | 5. Rear Shroud            |
| 2. Front Shroud         | 6. Drive Wheel            |
| 3. Caster Wheels        | 7. Reset Lever            |
| 4. Main Circuit Breaker | 8. Manual Shut-Off Button |



Main Circuit Breaker

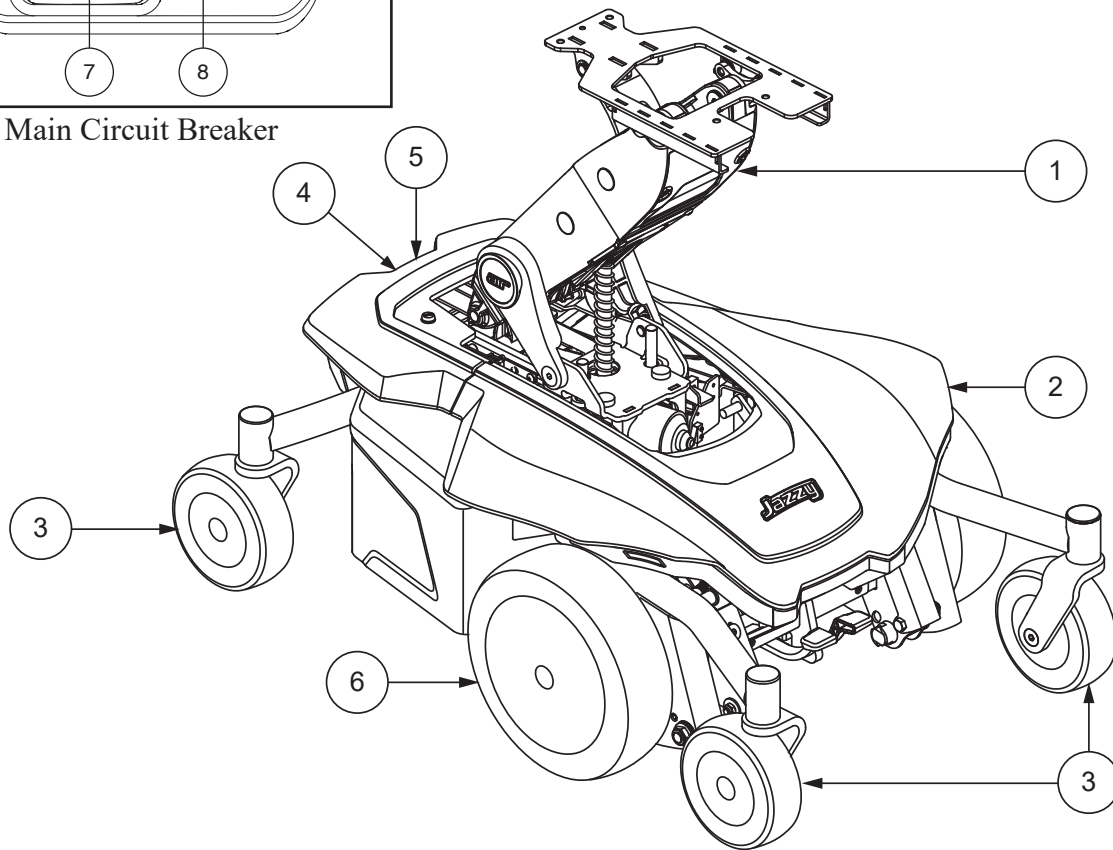

Figure 2. The Jazzy Air® Series Power Base

## Electrical Components

The electrical components are located either on or inside the power base. The main circuit breaker is located on the side of the power base. The power module is located under the front shroud. **See figure 3.**

**Main Circuit Breaker (Reset Button):** When the voltage in the batteries becomes low or your vehicle is heavily strained because of excessive loads, the main circuit breaker may trip to protect the motor and electronics from damage. When the breaker trips, the entire electrical system shuts down. **See figure 2.**

- The reset button pops out when the breaker trips.
- Allow a minute or so for the electronics to “rest.”
- Push in the reset button to reset the breaker.
- If the breaker trips frequently, you may need to charge the batteries more often.
- If the main circuit breaker trips repeatedly, see your authorized dealer for service



# III. YOUR POWER CHAIR

In the event of an electrical fault or a thermal event, the battery power can be quickly disconnected. The batteries should be isolated for transport to service.



**WARNING!** When faced with an emergency situation, the batteries can be quickly disconnected by pressing the manual shut-off button on the circuit breaker. See figure 2. Use caution. Be advised that turning off power to the power chair may cause the power chair to stop abruptly. To release the emergency stop and restore driving capability to the power chair, follow the circuit breaker reset instructions.

**Power Module:** Provides connection between the joystick module and the motors, batteries, and off-board charger.

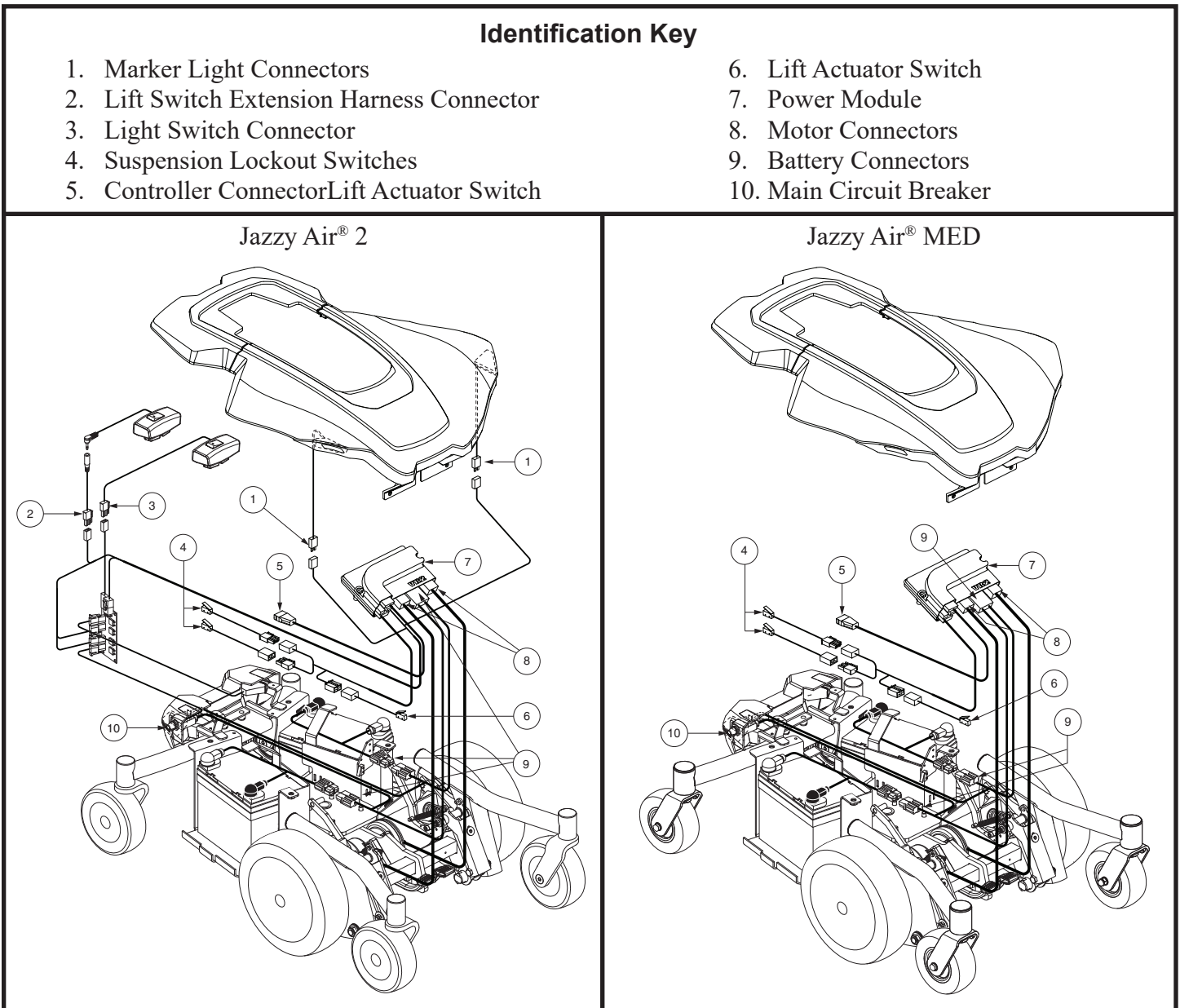

Figure 3. The Jazzy Air® Series Electrical Components

# III. YOUR POWER CHAIR

## Manual Freewheel Levers

Your power chair has a manual freewheel lever on each motor. Manual freewheel levers enable you to disengage the drive motors from the gearboxes and maneuver the chair manually.



**WARNING! Do not use the power chair while the drive motors are disengaged! Do not disengage the drive motors when the power chair is on an incline or decline, as the unit could roll on its own. Only engage the freewheel mode when on a level surface.**



**WARNING! It is important to remember that when your power chair is in freewheel mode, the braking system is disengaged.**

### To engage or disengage the drive motors:

1. Locate the levers at the front of the power base.
2. Pull both levers upward to engage the drive motors (drive mode). See figure 4.
3. Push both levers downward to disengage the drive motors (freewheel mode). See figure 5.

If a lever is difficult to move in either direction, slightly rock the power chair back and forth. The lever should then move to the desired position.

**WARNING! Avoid applying excessive force to the manual freewheel levers.**



**WARNING! Do not use your foot to operate the manual freewheel levers. Do not stand on the manual freewheel levers. Applying excessive force to the manual freewheel levers may result in damage to the freewheel levers, motors, and brakes.**

**WARNING! Do not use the freewheel lever handles as tie-down points to secure this product.**

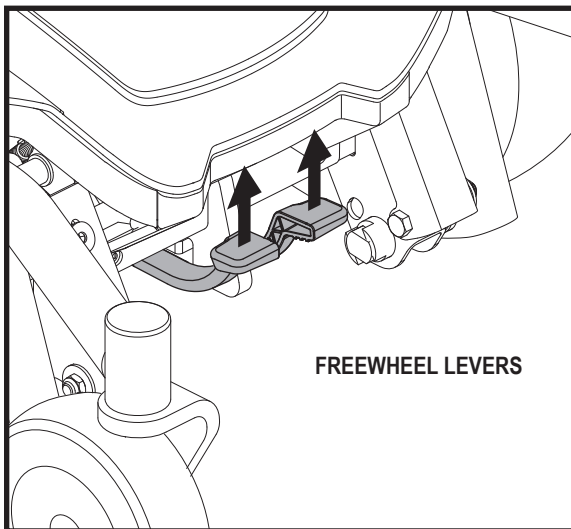

Figure 4. Drive Mode (Drive Engaged)

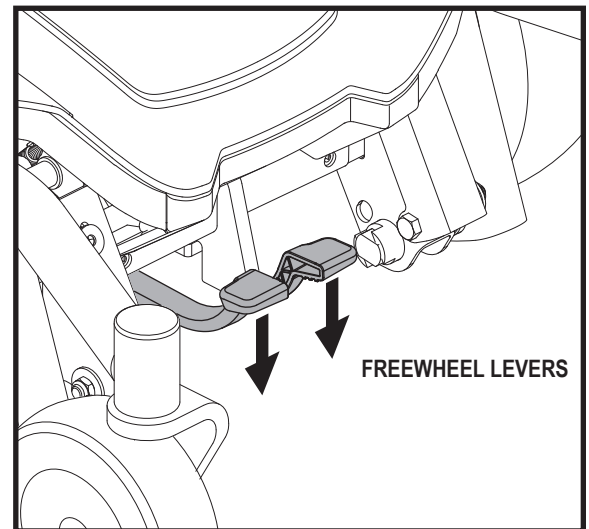

Figure 5. Freewheel Mode (Drive Disengaged)

# III. YOUR POWER CHAIR

## Power Chair Securement Points

The power chair is equipped with four (4) tie-down points for the purpose of securing the unoccupied power chair during motor vehicle transport. Each tie-down point is clearly labeled for this purpose.

### To secure a power chair equipped with tie-down points:

- Always secure the power chair in a forward-facing position in the vehicle.
- Attach the four tie-down straps to only designated, labeled transit securement points indicated by anchor symbols on the power chair. See figures 6 and 7. Tighten the straps to sufficiently remove all slack.
- Never attach tie-downs to adjustable, moving, or removable parts of the power chair such as armrests, front riggings, and wheels.
- Position the anchor points for the rear tie-down straps directly behind the rear securement points on the power chair. The front tie-down straps should be anchored to floor points that are spaced wider than the power chair to provide increased stability. See figure 7.



**MANDATORY!** The power chair should be used as indicated in the manufacturer's instructions. If you have any questions about the proper use of your power chair, contact your authorized Pride Provider.

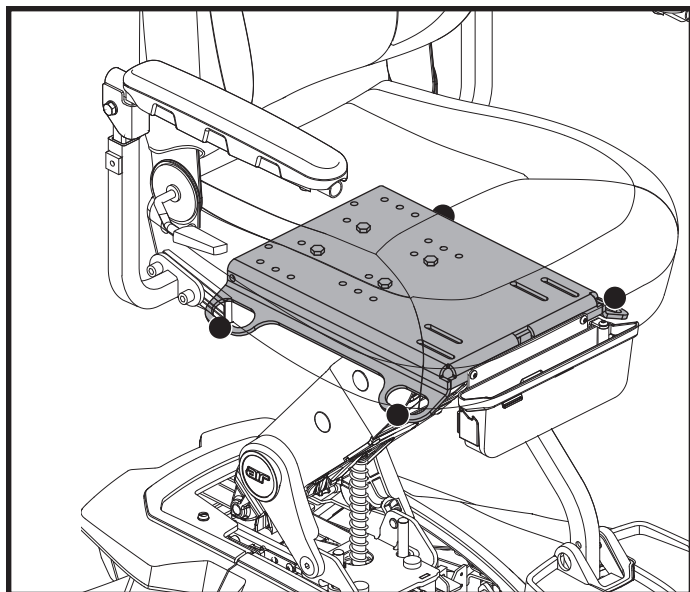

Figure 6. Transit Securement Brackets

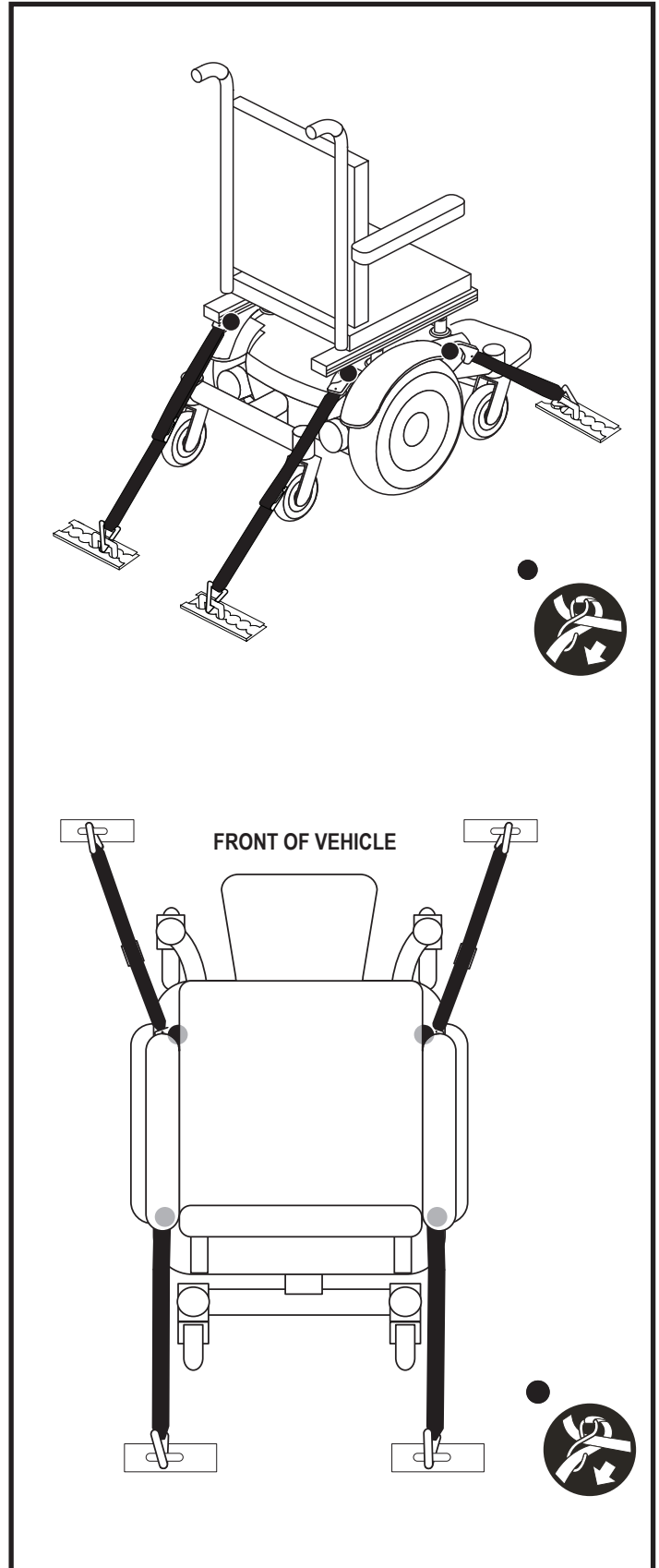

Figure 7. Unoccupied Transit System Securement Points

# III. YOUR POWER CHAIR

## Jazzy Air® Series

Your power chair is equipped with the Jazzy Air® elevation feature. The Jazzy Air® elevation feature is mounted on a Jazzy power base for maximum stability when the seating system is elevated. See figure 8.



**MANDATORY!** Before operating the Jazzy Air® elevation feature, read the following. These guidelines are provided for your benefit and will aid you in the safe operation of the Jazzy Air® elevation feature.

- Ensure the power is turned off before you are seated in your power chair.
- Always have assistance when you are being seated in or transferring to your power chair.
- Follow all of the procedures and heed the warnings as explained in this owner's manual, supplemental manuals, and the Consumer Safety Guide.

**WARNING!** The center of gravity of your power chair was factory set to a position that meets the needs of the demographic majority of users. Your authorized Pride Provider has evaluated your power chair and made any necessary adjustments to suit your specific requirements. Do not change your seating configuration without first contacting Pride Mobility Products or your authorized Pride Provider.



**WARNING!** Some power chair components are heavy. You may need assistance to lift or carry them. Please refer to the specifications table for specific component weights before you disassemble the power chair.

**WARNING!** Do not pick up the seat frame by the armrests. They are free to pivot, and you may lose control of the seat if they do so.

**WARNING!** Remove the occupant from the power chair before making any adjustments.

*NOTE: The Jazzy Air® elevation feature is automatically engaged when the power elevating seat is activated.*

The Jazzy Air® elevation feature is accessed through the controller or a single switch, and the power chair must be on a flat, level surface to activate Jazzy Air®.

*NOTE: Placing the single switch on the outside of the power chair, for example, on the side rail, may increase the overall width of the power chair.*



**WARNING!** The single switch should be mounted in a location that is convenient for the power chair user and where the switch harness will not be caught in drive tires or running gear, pinched in the seat frame, or damaged when passing through doorways.

*NOTE: For more information on the Jazzy Air® series warning displays, refer to the basic operation instructions for your controller.*

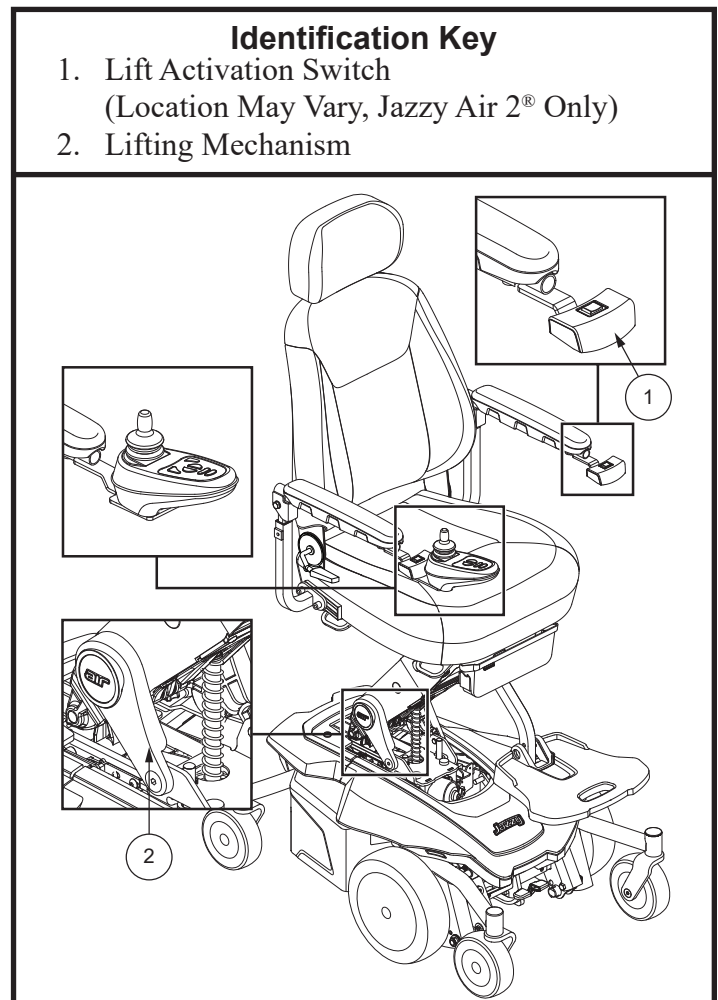

Figure 8. Jazzy Air® Elevation Feature (Jazzy Air® 2 Shown)

# III. YOUR POWER CHAIR

The Jazzy Air® elevation feature should be used only on flat, level, indoor surfaces, such as in malls, offices, and/or medical facilities.

While the Jazzy Air® elevation feature is in use, the power chair can drive at a predetermined, safe speed. Refer to the product specifications sheet insert for more information on the reduction of the maximum speed.



**PROHIBITED!** Never use the Jazzy Air® elevation feature outdoors on uneven terrain (gravel, hills or other uneven, non-compact terrain) or in fields.

**WARNING!** The Jazzy Air® elevation feature should be used only on flat, level, indoor surfaces, such as in malls, offices, and/or medical facilities. Never raise the seat from its lowest position on an inclined or uneven surface or while attempting to negotiate or climb/descend a raised or lowered surface. Failure to heed this warning can result in the power chair tipping over.

**WARNING!** The Jazzy Air® elevation feature is intended for limited outdoor use on only flat, level, hardscape surfaces. If you are unsure of your environment, do not use the Jazzy Air® elevation feature outdoors.



**WARNING!** Never raise the seat on the Jazzy Air® series when operating your power chair on bumpy or uneven surfaces. Failure to heed this warning can result in the power chair tipping over.

**WARNING!** Always fasten the positioning belt when operating the power chair.

**WARNING!** Do not operate the Jazzy Air® elevation feature or change the seat height in any way while your power chair is positioned under a fixed object, such as a table or desk. Keep area clear prior to and during movement.

*NOTE: The Jazzy Air® elevation feature is equipped with a system that allows the power chair to drive at a predetermined, safe speed when the chair is elevated. Always check to be sure this system is operating properly before using your power chair.*

## Marker Lights (If Equipped)

The Jazzy Air® 2 is equipped with marker lights. The lights are composed of white LEDs in the front and red LEDs in the rear and are mounted on the shroud of your power base. See figure 1.

The marker lights operate through a toggle switch that is mounted to an armrest.

### To operate the marker lights:

1. Press the toggle switch to activate the marker lights. A light on the toggle will illuminate when the marker lights are activated.
2. Press the toggle switch again to deactivate the marker lights.

*NOTE: Turn off marker lights when the power chair is not in use to optimize power chair performance per charge.*

## Storage Compartment (If Equipped)

The Jazzy Air® 2 is equipped with one swing-away storage compartment, located beneath the front of the seat.

### To access swing-away storage:

1. Pull the storage handle upward and outward to release it from the latch.
2. Swing the storage compartment to the open position. See figure 9.



**WARNING!** Always ensure that the swing away storage compartment is secured in the closed position before operating your power chair.

## III. YOUR POWER CHAIR

You may need to remove the swing-away storage compartment to install additional power chair accessories.

**To remove the swing-away storage compartment:**

1. Open the storage compartment by pulling the storage handle upward and outward. **See figure 9.**
2. Swing the storage compartment away from the two bolts securing the bracket to the seat frame.
3. Remove the two bolts from the storage bracket. **See figure 9.**

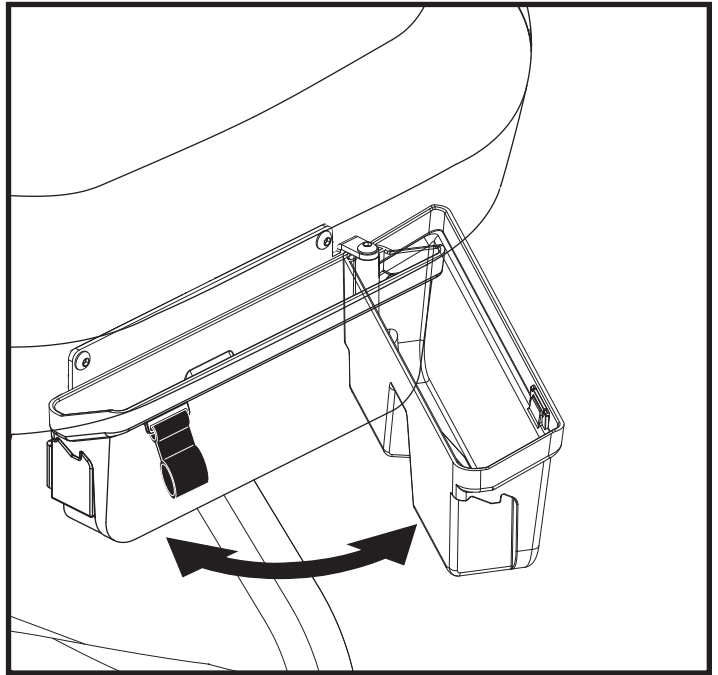

**Figure 9. Swing-away Storage Compartment**

# IV. ASSEMBLY

## INITIAL ASSEMBLY

Your power chair may require some assembly either before initial use or after transportation. It may also require disassembly to make some comfort adjustments.

### Seat Installation

It may be necessary to install the seat either prior to initial operation or after transporting your power chair.

**NOTE:** Any nylon insert lock nut removed during the disassembly or adjustment of the power chair must be replaced with a new nylon insert lock nut. Nylon insert lock nuts should not be reused as it may cause damage to the nylon insert, resulting in a less secure fit. Replacement nylon insert lock nuts are available at local hardware stores or through your authorized Pride Provider.

#### To install the seat:

1. Remove the shrouds from the power chair.
2. Remove the right battery cover.
3. Connect the battery.
4. Press the on/off button to power on controller.
5. Press actuator button. The Mode LED should illuminate.
6. Using the controller, raise the actuator to highest position.
7. Press the on/off button to power down.
8. Place the seat onto the seat plate.



**WARNING!** Do not pick up the seat frame by the armrests. They are free to pivot, and you may lose control of the seat if they do so.

9. Tip the seat backward. Insert the front bolt with washer through the slot in the seat plate and align with tapped hole in the underside of the seat. Start tightening by hand, leaving the bolts loose. See **figure 10**.
10. Repeat step 9 for other side.
11. Slide seat forward or backward to align rear bolt holes with washer to the desired position. Start tightening by hand.
12. Tighten all of the bolts with the provided hex key.
13. Place armrests into the receivers and tighten setscrews at desired height.
14. Place the headrest into the back of the seat and adjust to the desired height.
15. With the armrest lowered, install the controller on the desired armrest. Adjust the controller to the desired position and then tighten setscrew.
16. Route the controller and lighting harnesses along the inside of the armrest.
17. Secure the harnesses on the armrest with the supplied wire-ties as shown in **figure 11**.
18. Flip up the armrest.
19. Secure the harnesses along the armrest receiver and seat plate with supplied wire-ties as shown in **figure 11**.
20. Ensure the armrest can freely be raised and lowered without any tension on the harnesses so they do not become disconnected.

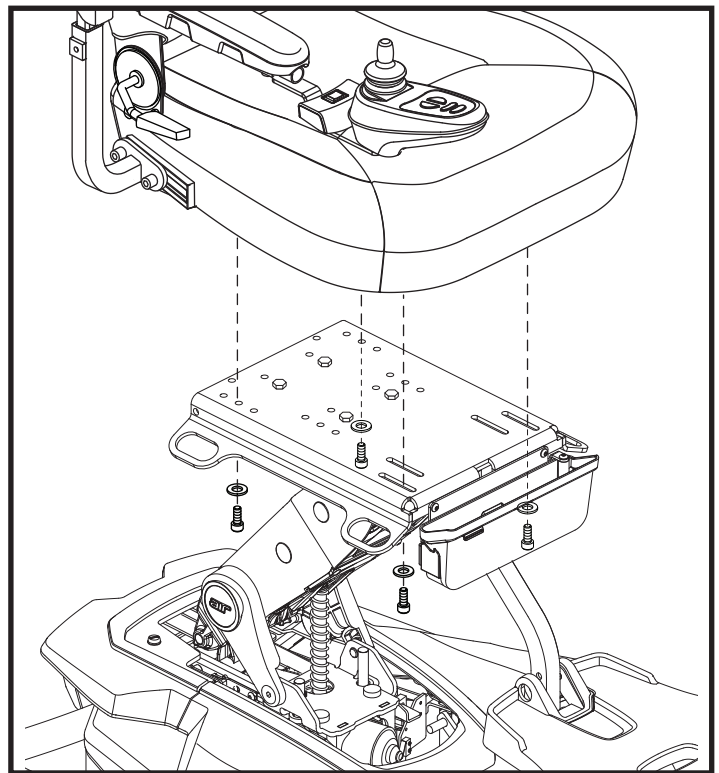

**Figure 10. Seat Installation**

## IV. ASSEMBLY

21. Repeat steps 16 through 20 for the other armrest and single switch harness.
22. Reinstall the battery cover and then the top shroud.



**WARNING! Ensure that the harnesses are secure and cannot be entangled in the drive wheels or lifting mechanism.**

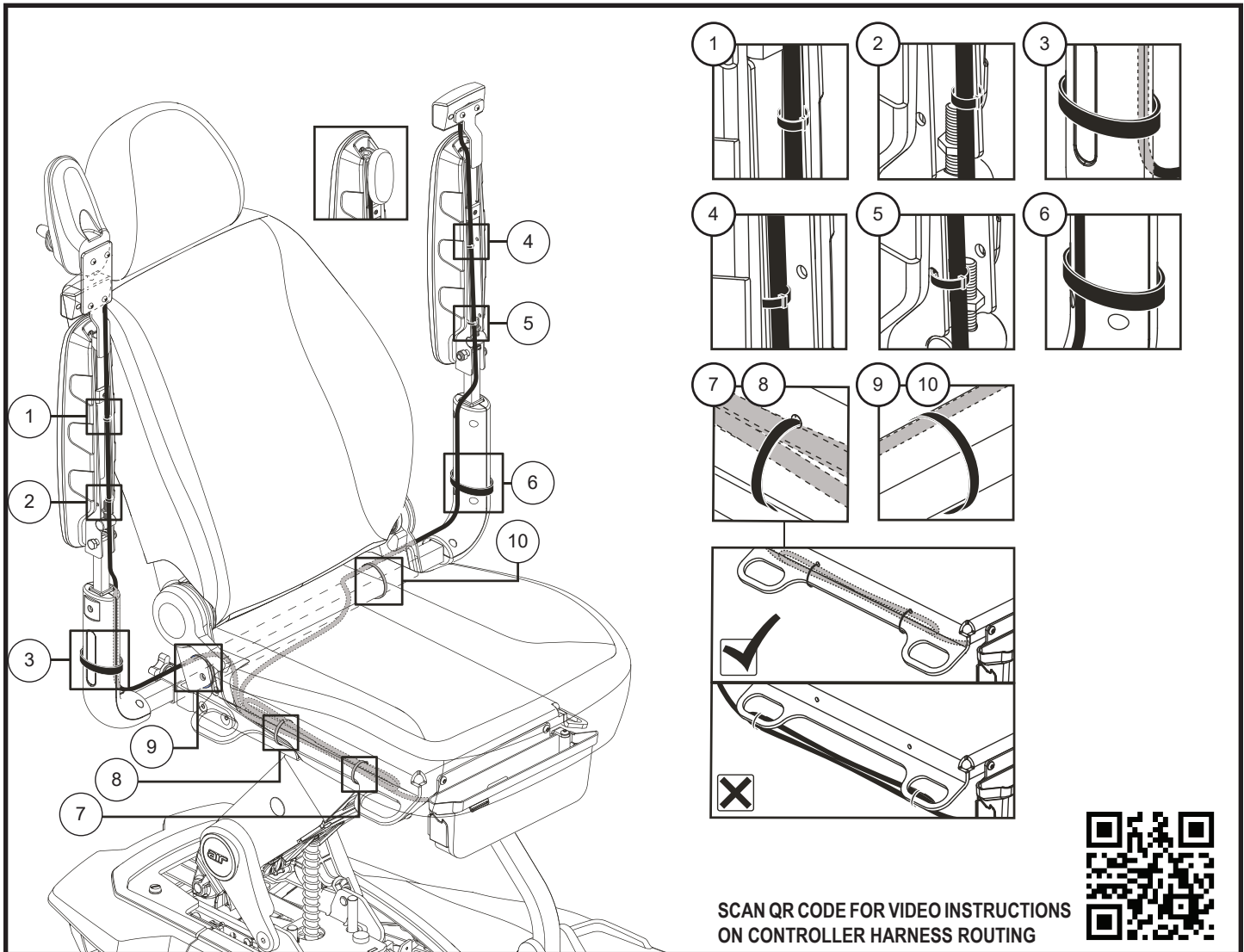

SCAN QR CODE FOR VIDEO INSTRUCTIONS  
ON CONTROLLER HARNESS ROUTING

Figure 11. Controller Harness Routing



**WARNING! Ensure that all harnesses are properly routed as shown in figure 11. Improper routing can cause damage to the light switch, controller, or other electrical components.**

To secure the harnesses:

1. For locations 1 through 10, tighten the wire-ties into place according to the proper harness routing shown in figure 11.



**WARNING! The wire-ties should be snug but not overtightened as damage to the harnesses or power chair may result.**

**NOTE:** For video instructions on routing the controller harness, visit <https://youtu.be/KHdTQK9KXn0> or scan the QR code shown in figure 11 with your smartphone device.



# V. COMFORT ADJUSTMENTS

## COMFORT ADJUSTMENTS

After becoming familiar with your power chair's operation, you may find the need to make some adjustments to increase your comfort, such as armrest angle, foot platform height and angle, and controller position. Refer to the following information before making comfort adjustments.

**NOTE:** Any nylon insert lock nut removed during the disassembly or adjustment of the power chair must be replaced with a new nylon insert lock nut. Nylon insert lock nuts should not be reused as this may cause damage to the nylon insert, resulting in a less secure fit. Replacement nylon insert lock nuts are available at local hardware stores or through your authorized Pride Provider.

**NOTE:** If your power chair is equipped with an optional seating system, please refer to the information provided in separate manuals.

**WARNING!** The center of gravity of your power chair was factory set to a position that meets the needs of the demographic majority of users. Your authorized Pride Provider has evaluated your power chair and made any necessary adjustments to suit your specific requirements. Do not change your seating configuration without first contacting Pride Mobility Products or your authorized Pride Provider.



**WARNING!** Some power chair components are heavy. You may need assistance to lift or carry them. Please refer to the specifications table for specific component weights before you disassemble the power chair.

**WARNING!** Do not pick up the seat frame by the armrests. They are free to pivot, and you may lose control of the seat if they do so.

**WARNING!** Remove the occupant from the power chair before making any adjustments.

### Manual Recline Seatback Adjustment

If your power chair is equipped with a manual recline seatback, you can adjust the seatback angle using the seatback release lever. See figure 12.

**To adjust the recline angle using the seatback release lever:**

1. Pull up on the seatback release lever.
2. Lean forward or backward to the desired position.
3. Release the lever.

### Armrest Angle Adjustment

**To change the armrest angle:**

1. Lift the armrest straight up so that it is perpendicular to the floor. See figure 12.
2. Loosen the jam nut, if equipped.
3. Turn the adjusting screw to raise or lower the front of the armrest.
4. Tighten the jam nut, if equipped, to lock the adjusting screw into place.

### Armrest Height Adjustment

**To change the armrest height:**

1. Loosen the setscrews on the armrest. See figure 12.
2. Raise or lower the armrest to the desired height.
3. Tighten the setscrews to secure the armrest.

# V. COMFORT ADJUSTMENTS

## Identification Key

- |                                     |                              |
|-------------------------------------|------------------------------|
| 1. Jam Nut                          | 5. Mounting Bracket Receiver |
| 2. Armrest Angle Adjustment Screw   | 6. Setscrew                  |
| 3. Armrest Height Adjustment Screws | 7. Seatback Release Lever    |
| 4. Armrest Knob                     |                              |

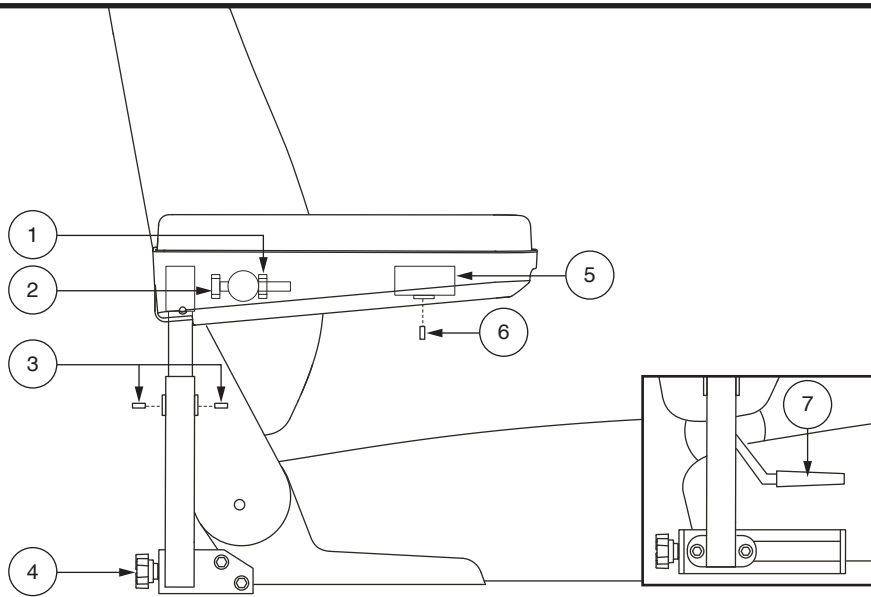

Figure 12. Armrest and Seatback Adjustments

## Controller Position

You can move the controller in toward or out away from the armrest, or change the position of the controller for either left-hand or right-hand use.



**MANDATORY! Prevent controller harness damage! Avoid routing the controller harness on the outside of the armrest pad. Route the harness under the armrest or toward the inside of the armrest pad. Use correct tie-down points for the controller harness to prevent the harness from getting caught in the drive tires, pinched in the seat frame, or damaged when passing through doorways.**

### To extend the controller:

1. Turn off the power to the controller.
2. Flip up the armrest so it is perpendicular to the floor.
3. Loosen the setscrew on the controller bracket. **See figure 12.**
4. Slide the controller into or out of the armrest to the desired position.
5. Tighten the setscrew to secure the controller.

### To change the controller position:

1. Turn off the power to the controller.
2. Unplug the controller harness from the power base.
3. Cut the wire tie(s) that secure the controller harness to the armrest and seat.
4. Flip up the armrests.
5. Loosen the setscrew on the underside of each armrest. **See figure 12.**
6. Slide the controller out of the armrest.
7. Place the controller into the other armrest.
8. Tighten the setscrew to secure the controller.
9. Route the controller harness along the seat frame and secure with wire ties. **See figure 11.**
10. Plug the controller into the power base. **See figure 3.**

# V. COMFORT ADJUSTMENTS

## Foot Platform Height Adjustment

The foot platform height is easily adjusted to different heights in 0.5-in. (1.27-cm) increments.

### To raise or lower the foot platform:

1. Remove the hardware from the foot platform support. See figure 13.
2. Raise or lower the foot platform to the desired height.
3. Reinstall the hardware into the foot platform support and tighten.

## Foot Platform Angle Adjustment

You can adjust the angle of the foot platform. See figure 13.

### To adjust the foot platform angle:

1. Flip up the foot platform and locate the angle adjustment screw.
2. Turn the angle adjustment screw to raise or lower the front of the foot platform.

## Positioning Belt

Your power chair may be equipped with a positioning belt that can be adjusted for operator comfort. See figure 14. The positioning belt is designed to support the operator so that he/she does not slide down or forward in the seat. The positioning belt is not designed for use as a restraining device.

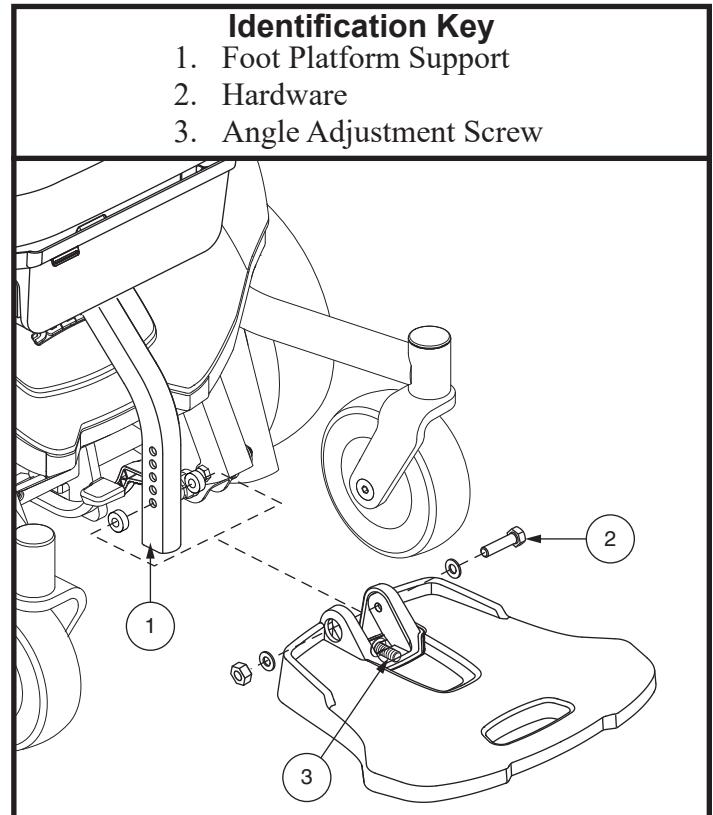

Figure 13. Foot Platform Adjustment

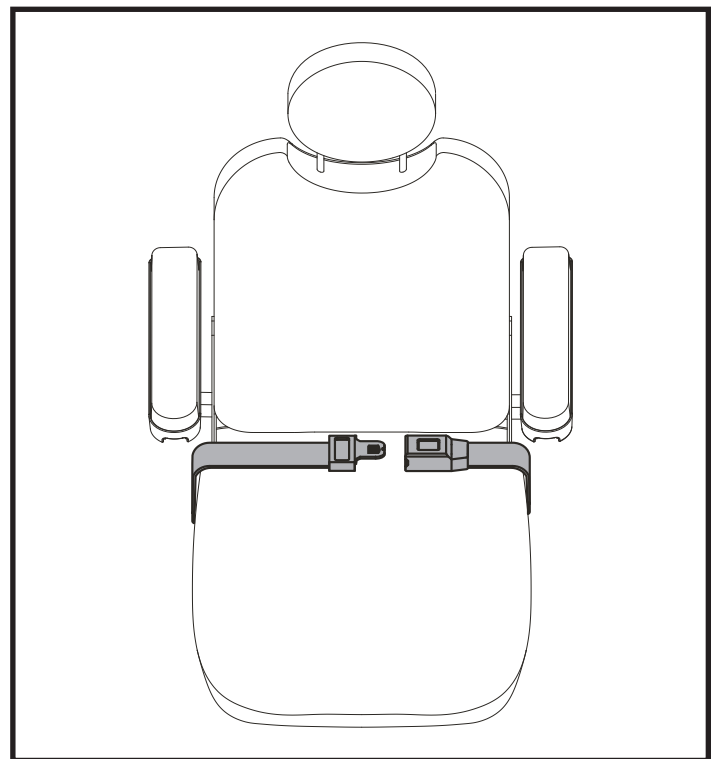

Figure 14. Positioning Belt Adjustment

# V. COMFORT ADJUSTMENTS



**WARNING!** The positioning belt is not designed for use as a seat belt in a motor vehicle. Anyone traveling in a vehicle should be properly belted into seats approved by the vehicle manufacturer. Your power chair is not suitable for use as a seat in any vehicle with the following exception: The vehicle must be equipped with a Wheelchair Tie-down and Occupant Restraint System (WTORS) that has been installed in accordance with the tie-down manufacturer's instructions, and is compliant with ANSI/RESNA WC/ Vol. 4, Section 18/ISO 10542 standards, and the power chair must have a transit securement system conforming to ANSI/RESNA WC/ Vol. 4, Section 19/ISO 7176 standards. It is essential to use a complete WTORS to secure the power chair to the vehicle and to provide the power chair occupant with a properly designed and tested safety restraint system. A restraint system with both pelvic and upper-torso belts must be used to protect the power chair occupant and minimize the likelihood of injury caused by contact with the vehicle during a crash or sudden braking.

**WARNING!** The positioning belt should be secured at all times. Never allow the positioning belt to hang or drag on the floor as it may become entangled.

## To install the positioning belt:

1. Remove the rearmost screw that holds the seat hinge to the seat base on both the left and right seat hinges.
2. Insert the screw through the supplied washer, through the positioning belt, and into the seat base for each side of the power chair seat.
3. Tighten both screws.

## To adjust the positioning belt for operator comfort:

1. Once seated, insert the metal tab on one side of the belt into the plastic housing on the opposite side until you hear a click. See figure 14.
2. Pull the excess strap attached to the metal tab until it is secure, but not so tight as to cause discomfort.

## To release the positioning belt:

1. Press the push button mechanism on the plastic housing.



**MANDATORY!** Make sure the positioning belt is properly secured to the power chair and is adjusted for operator comfort before each use.

**MANDATORY!** Inspect the positioning belt for loose parts or damage, including tears, worn spots, bent hardware, damaged latch mechanisms, dirt or debris, before each use of the power chair. If you discover a problem, contact your authorized Pride Provider for maintenance and repair.

# VI. BATTERIES AND CHARGING

## BATTERIES AND CHARGING

Your power chair uses two long-lasting, 12-volt, deep-cycle batteries. These batteries are sealed and maintenance free. Since they are sealed, there is no need to check the electrolyte (fluid) level. Deep-cycle batteries are designed to handle a longer and deeper discharge. Though they are similar in appearance to automotive batteries, they are not interchangeable. Automotive batteries are not designed to handle a long, deep discharge, and also are unsafe for use in power chairs.



**MANDATORY!** Battery posts, terminals, and related accessories contain lead and lead compounds. Wear goggles and gloves when handling batteries and wash hands after handling.



**PROHIBITED!** Always use two batteries of the exact same type, chemistry, and amp-hour (Ah) capacity. Refer to the specifications table in this manual and in the manual supplied with the battery charger for recommended type and capacities.



**WARNING!** Contact your authorized Pride Provider if you have any questions regarding the batteries in your power chair.

## Charging the Batteries

The battery charger is essential in providing long life for your power chair batteries. It is designed to optimize your power chair's performance by charging the batteries safely, quickly, and easily. The battery charger is only functional when the charger power cord is plugged into an electrical outlet.



**PROHIBITED!** Removal of grounding prong can create electrical hazard. If necessary, properly install an approved 3-pronged adapter to an electrical outlet having 2-pronged plug access.



**PROHIBITED!** Never use an extension cord to plug in your battery charger. Plug the charger directly into a properly wired standard electrical outlet.



**PROHIBITED!** Do not allow unsupervised children to play near the power chair while the batteries are charging. Pride recommends that you do not charge the batteries while the power chair is occupied.



**MANDATORY!** Read the battery charging instructions in this manual and in the manual supplied with the battery charger before charging the batteries.



**WARNING!** Explosive gases may be generated while charging the batteries. Keep the power chair and battery charger away from sources of ignition such as flames or sparks and provide adequate ventilation when charging the batteries.

**WARNING!** You must recharge your power chair's batteries with the supplied off-board battery charger. Do not use an automotive-type battery charger.

**WARNING!** Inspect the battery charger, wiring, and connectors for damage before each use. Contact your authorized Pride Provider if damage is found.



**WARNING!** Do not attempt to open the battery charger case. If the battery charger does not appear to be working correctly, contact your authorized Pride Provider.

**WARNING!** Be aware that the battery charger case may become hot during charging. Avoid skin contact and do not place on surfaces that may be affected by heat.

**WARNING!** If the battery charger is equipped with cooling slots, then do not attempt to insert objects through these slots.



**WARNING!** If your battery charger has not been tested and approved for outdoor use, then do not expose it to adverse or extreme weather conditions. If the battery charger is exposed to adverse or extreme weather conditions, then it must be allowed to adjust to the difference in environmental conditions before use indoors. Refer to the manual supplied with the battery charger for more information.

# VI. BATTERIES AND CHARGING

**To charge the batteries using the off-board charger:**

1. Position the front of your power chair next to a standard electrical outlet.
2. Be certain the controller power is turned off and the freewheel levers are in the engaged position. See III. "Your Power Chair."
3. Plug the off-board charger into the off-board charger/programming socket on the controller. See figure 15.
4. Plug the off-board charger into the electrical outlet.



**WARNING! The LED lights on the charger indicate different charger conditions at various times: charger power on, charging in progress, and charging complete. If the LED does not indicate that charging is complete within 24 hours, unplug the charger and contact your authorized Pride Provider. Refer to the manual supplied with the charger for a complete explanation of these indicators.**

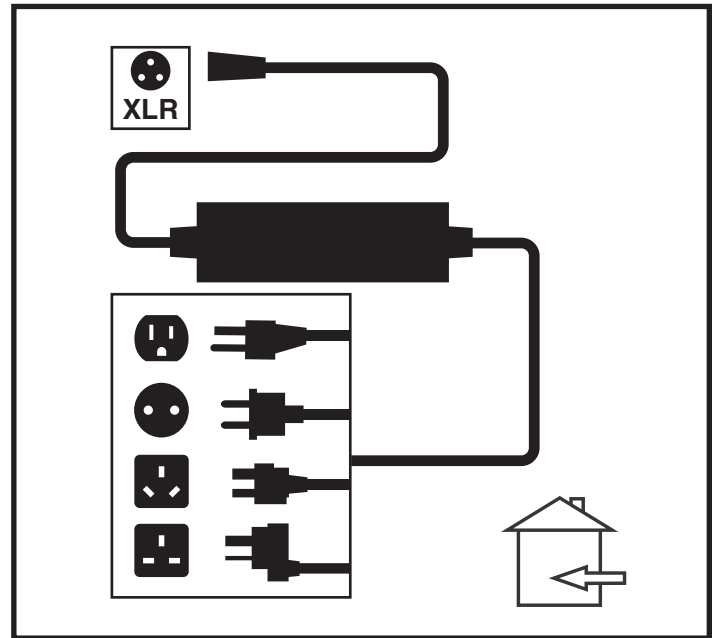

Figure 15. Battery Charging

5. When the batteries are fully charged, unplug the off-board charger from the electrical outlet and then from the controller.

## Battery Break-in

**To break in new batteries for maximum efficiency:**

1. Fully recharge any new battery prior to its initial use. This brings the battery up to about 90% of its peak performance level.
2. Operate your power chair throughout the house and yard. Move slowly at first, and do not travel too far until you become accustomed to the controls and break in the batteries.
3. Give the batteries another full charge of at least 8 to 14 hours and operate your power chair again. The batteries will now perform at over 90% of their potential.
4. After four or five charging cycles, the batteries will top off at 100% charge and last for an extended period.

## Frequently Asked Questions (FAQs)

### How does the charger work?

The battery charger takes the standard electrical outlet voltage (alternating current) and converts it to 24V DC (direct current). The power chair batteries use direct current to run your power chair. When the battery voltage is low, the charger works harder to charge the battery. As the battery voltage approaches full charge, the charger doesn't work as hard to complete the charging cycle. When the battery is fully charged, the amperage from the charger is nearly at zero. This is how the charger maintains a charge but does not overcharge the battery.

### Can I use a different battery charger?

You should use the charger supplied with the power chair. It is the safest, most efficient tool to charge the batteries. We do not recommend using other types of chargers (e.g., an automotive battery charger).

## VI. BATTERIES AND CHARGING

**NOTE:** Your power chair's charger will not operate after the batteries have been discharged to nearly zero voltage. If this happens, call your authorized Pride Provider for assistance.

### How often must I charge the batteries?

Many factors come into play when deciding how often to charge the batteries. You may use your power chair all day on a daily basis or you may not use it for weeks at a time.

#### ■ Daily Use

If you use your power chair on a daily basis, charge the batteries as soon as you are finished using your power chair. Your power chair will be ready each morning to give you a full day's service. It is recommended that you charge the batteries at least 8 to 14 hours after daily use. Pride recommends that you charge the batteries for an additional 4 hours after the battery charger indicates the charging is complete.

#### ■ Infrequent Use

If you use your power chair infrequently (once a week or less), you should charge the batteries at least once per week for at least 24 hours.

**NOTE:** Keep your batteries fully charged and avoid deeply discharging your batteries. Refer to the manual supplied with the battery charger for charging instructions. Pride recommends charging your batteries for at least 48 continuous hours once per month to improve battery performance and battery life.

### How can I get maximum range or distance per charge?

Rarely do you have an ideal driving situation such as smooth, flat, hard terrain with no hills or curves. More often you are presented with hills, sidewalk cracks, uneven and loosely packed surfaces, and curves. All of these factors will affect the distance or running time per battery charge. Below are a few suggestions for obtaining the maximum range per charge:

- Always charge the batteries fully prior to your trip.
- Plan your trip in advance to avoid inclines if possible.
- Limit baggage weight to essential items.
- Try to maintain an even speed and avoid stop-and-go driving.
- Pride recommends charging your batteries for at least 48 continuous hours once per month to improve battery performance and battery life.

### What type of batteries should I use?

We recommend deep-cycle batteries that are sealed and maintenance free. Both AGM and Gel-Cell are deep-cycle batteries that are similar in performance.



**WARNING! Corrosive chemicals contained in batteries. Use only AGM or Gel-Cell batteries to reduce the risk of leakage or explosive conditions.**

### Why do my new batteries seem weak?

Deep-cycle batteries employ a much different chemical technology than that used in car batteries, nickel-cadmium (nicads), or in other common battery types. Deep-cycle batteries are specifically designed to provide power, drain down their charge, and then accept a relatively quick recharge. AGM and Gel-Cell batteries should be charged as often as possible. They do not have a "memory" like nickel-cadmium batteries.

## VI. BATTERIES AND CHARGING

We work closely with our battery manufacturer to provide a battery that best suits your power chair's specific demands. Fresh batteries arrive regularly at Pride and are promptly shipped with a full charge. During shipping, the batteries encounter temperature extremes that may influence initial performance. Heat robs the charge from the battery, and cold slows the power available and extends the time needed to recharge the battery (just as with a car battery).

It might take a few days for the temperature of the battery to stabilize and adjust to its new ambient temperature. More importantly, it will take a few "charging cycles" (a partial drain—then a full recharge) to establish the critical chemical balance that is essential to the battery's peak performance and long life. It will be well worth it to take the time to break in your battery properly.

### How can I ensure maximum battery life?

A fully charged deep-cycle battery will provide reliable performance and extended battery life. Keep your power chair's batteries fully charged whenever possible. Batteries that are regularly and deeply discharged, infrequently charged, or stored without a full charge may be permanently damaged, causing unreliable power chair operation and limited battery life.

*NOTE: The useful life of a battery is quite often a reflection of the care it receives.*

### How should I store my power chair and its batteries?

If you do not use your power chair regularly, we recommend maintaining battery vitality by charging the batteries at least once per week.

If you do not plan on using your power chair for an extended period, fully charge the batteries prior to storage. Disconnect the battery harnesses and store the power chair in a warm, dry environment. Avoid temperature extremes, such as freezing and excessively hot conditions, and never attempt to charge a frozen battery. A cold or frozen battery should be warmed for several days prior to recharging.

### What about public transportation?

AGM and Gel-Cell batteries are designed for application in power chairs and other mobility vehicles. These batteries are Federal Aviation Administration (FAA) approved, allowing safe transportation on aircraft, buses, and trains, as there is no danger of spillage or leakage. We suggest you contact the carrier's ticket counter in advance to determine that carrier's specific requirements.

### What about air travel?

Your power chair is labeled to indicate if the batteries are tested and comply with United Nations Transport Regulation standard UN38.3. Refer to the battery box of your power chair to determine if the battery is rated for air travel.



**Indicates that the battery in your power chair has been tested and complies with United Nations Transport Regulations standard UN38.3. We suggest you contact the carrier's ticket counter in advance to determine that carrier's specific requirements, and to ensure your power chair and its battery are permitted.**



**Indicates that the battery in your power chair does NOT comply with United Nations Transport Regulations standard UN38.3.**

### What about shipping?

If you wish to use a freight company to ship your power chair to your final destination, repack your power chair in the original shipping container, if possible, and ship the batteries in separate boxes.



# VII. CARE AND MAINTENANCE

## CARE AND MAINTENANCE

Your Jazzy Air® series power chair is a sophisticated device. Like any motorized vehicle, it requires routine maintenance checks. You can perform some of these checks, but others require assistance from your authorized Pride Provider. Preventive maintenance is very important. If you follow the maintenance checks in this section as scheduled, you can help ensure that your power chair gives you years of trouble-free operation. If you have any doubt as to your power chair's care or operation, contact your authorized Pride Provider.



**WARNING! Do not service the power chair when the seat is occupied.**

Your power chair, like most electrical equipment, is susceptible to damage from the elements. Avoid damp areas of any kind.



**WARNING! Direct or prolonged exposure to water or dampness could cause the power chair to malfunction electronically and mechanically. Water can cause electrical components to corrode and the chair's frame to rust. Power chairs should be examined periodically for signs of corrosion caused by water exposure, bodily fluid exposure, or incontinence. Damaged components should be replaced or treated immediately.**

### Should your power chair come in contact with water:

1. Dry your power chair as thoroughly as possible with a towel.
2. Allow your power chair to sit in a warm, dry place for 12 hours to allow unseen water to evaporate.
3. Check the joystick operation and the brakes before using your power chair again.
4. If any inconsistencies are found, take your power chair to your authorized Pride Provider. Power chairs that are frequently exposed to sources of water, such as incontinence, should be inspected often for corrosion and electronic components may need to be replaced frequently.

### Temperature

- Some of the parts of your power chair are susceptible to extreme changes in temperature. Always keep your power chair between the temperatures of -13°F (-25°C) and 122°F (50°C).
- In extremely cold temperatures the batteries may freeze. The specific temperature at which they freeze depends on a number of factors, such as battery charge, usage, and composition of the batteries (e.g., AGM or Gel-Cell).

### General Guidelines

- Avoid knocking or bumping the controller, especially the joystick.
- Avoid prolonged exposure of your power chair to extreme conditions, such as heat, cold, or moisture.
- Keep the controller clean.
- Check all connectors to ensure that they are all tight and secured properly.
- Make sure pneumatic tires are inflated to the psi/bar/kPa air pressure rating indicated on the tire.



**WARNING! Make sure your tires are inflated to the psi/bar/kPa air pressure rating indicated on the tire for pneumatic tires. Do not underinflate or overinflate your tires. Low pressure may result in loss of control, and overinflated tires may burst. Overinflating tires can cause them to explode.**

**WARNING! Do not use a high pressure hose to inflate your tires.**

- Use a rubber conditioner on the tire sidewalls to help preserve them.



**WARNING! Never use a rubber conditioner on the tread area of the tires; doing so may make the tires slippery and cause your power chair to skid.**

## VII. CARE AND MAINTENANCE

- All wheel bearings are prelubricated and sealed. They require no subsequent lubrication.
- If your power chair has a body shroud with a **glossy finish**, the body shroud has been sprayed with a clear sealant coating. You can apply a light coat of car wax to help it retain its high-gloss appearance. If your power chair has a body shroud with a **matte finish**, use **ONLY** products developed for matte-finish paint. Do not use wax, detail spray, ArmorAll®, or any product made for glossy paint.



**WARNING! Carefully choose the correct product to protect the finish of your power chair's shroud(s). ONLY products developed for matte-finish paint should be used on shrouds with a matte finish. Failure to follow this warning may result in damage to the shroud's matte paint finish.**

- Check all electrical connections. Make sure they are tight and are not corroded. Batteries must sit flat within the battery well frame with the battery terminals facing inward toward each other. Refer to the battery wiring label for the correct wiring layout.



**WARNING! Even though the power chair has passed the necessary testing requirements for ingress of liquids, you should keep electrical connections away from sources of dampness, including direct exposure to water or bodily fluids and incontinence. Check electrical components frequently for signs of corrosion and replace as necessary.**

### Daily Checks

- With the controller turned off, check the joystick. Make sure it is not bent or damaged and that it returns to the neutral position when you release it. Check the rubber boot around the base of the joystick for damage. Visually inspect the boot. Do not handle or try to repair it. See your authorized Pride Provider if there is a problem.
- Visually inspect the controller harness. Make sure that it is not frayed, cut, or has any wires exposed. See your authorized Pride Provider if there is a problem.
- Check for flat spots on solid tires. Flat spots could adversely affect stability.
- Inspect the seating system, armrests, and front riggings for loose hardware, stress points, or damage. See your authorized Pride Provider if there is a problem.

### Weekly Checks

- Disconnect and inspect the controller harness and the charger harness from the power base. Look for corrosion. Contact your authorized Pride Provider if necessary.
- Ensure that all parts of the controller system are securely fastened to your power chair. Do not overtighten any screws.
- Check for proper tire inflation. Maintain but do not exceed the psi/bar/kPa air pressure rating indicated on each tire for pneumatic tires. If a tire does not hold air, see an authorized Pride Provider for replacement of the tube.
- Check the brakes. This test should be carried out on a level surface with at least 1 meter (3 feet) of clearance around your power chair.

### To check the brakes:

1. Turn on the controller and turn down the speed level of your power chair.
2. After one second, check the battery condition meter. Make sure that it remains on.
3. Slowly push the joystick forward until you hear the electric brakes click. Immediately release the joystick. You must be able to hear each electrical brake operating within a few seconds of joystick movement. Repeat this test three times, pushing the joystick rearward, then left, and then right.

# VII. CARE AND MAINTENANCE

## Monthly Checks

- Check for drive tire wear. See your authorized Pride Provider for repair.
- Check the caster wheels for wear. Replace them as necessary.
- Check the caster forks for damage or fluttering which indicates that they may need to be adjusted or have the bearings replaced. See your authorized Pride Provider for repair.
- Check the entire power chair for loose hardware and changes in the function or performance of the power chair. See your authorized Pride Provider for service or repair.
- Keep your power chair clean and free of foreign material, such as mud, dirt, hair, food, drink, etc.

## Yearly Checks

Take your power chair to your authorized Pride Provider for yearly maintenance, especially if you use your power chair on a daily basis. This helps ensure that your power chair is functioning properly and helps prevent future complications.

## Storage

Your power chair should be stored in a dry place, free from temperature extremes. When storing, disconnect the batteries from the power chair. See VI. “Batteries and Charging.”



**WARNING! If you fail to store the unit properly, the frame can rust and the electronics can be damaged.**

Batteries that are regularly and deeply discharged, infrequently charged, stored in extreme temperatures, or stored without a full charge may be permanently damaged, causing unreliable performance and limited service life. It is recommended that you charge the batteries periodically throughout periods of prolonged storage to ensure proper performance.

You may wish to place several boards under the frame of your power chair to raise it off of the ground during periods of prolonged storage. This takes the weight off the tires and reduces the possibility of flat spots developing on the areas of the tires contacting the ground.

## Disposal of Your Power Chair

Your power chair must be disposed of according to applicable local and national statutory regulations. Contact your local waste disposal agency or authorized Pride Provider for information on proper disposal of power chair packaging, metal frame components, plastic components, electronics, batteries, neoprene, silicone, and polyurethane materials.

## Cleaning and Disinfection

- Use a damp cloth and mild, non-abrasive cleanser to clean the plastic and metal parts of your power chair. Avoid using products that may scratch the surface of your power chair.
- If necessary, clean your product with an approved disinfectant. Make sure the disinfectant is safe for use on your product before application.

**WARNING! Follow all safety instructions for the proper use of the disinfectant and/or cleaning agent before applying it to your product. Failure to comply may result in skin irritation or premature deterioration of upholstery and/or power chair finishes.**



**WARNING! Never hose off your power chair or place it in direct contact with water. Your power chair has a painted, ABS plastic body shroud that allows it to be easily wiped clean with a damp cloth.**

**WARNING! Never use any chemicals to clean a vinyl seat, as they may cause the seat to become slippery or dry out and crack. Use soapy water and dry the seat thoroughly.**

# VII. CARE AND MAINTENANCE

## How to Clean/Disinfect Equipment:

### Hard/Soft Surfaces

(Plastic shrouds, metal framing, seat fabric, tires, armrests and footplate mats, as applicable)

- For hard/soft surfaces, remove visible contamination if present.
  - For plastic and metal use Lysol®/Clorox® disinfecting spray/wipes and other qualified SARS-CoV-2 disinfecting products.
  - For other vinyl surfaces, clean with vinyl safe disinfecting wipes or solutions.
  - Suggested Disinfectants:
    - Birex® SE Disinfectant, Bleach-Rite® Disinfecting Spray, Citrace® Germicide.
    - Dispatch® Spray Hospital Cleaner Disinfectant with Bleach.
    - Diluted Bleach Solution (10% dilution or less); *NOTE:* Bleach with pH factor between 7 and 9 is suitable; a product with a pH of 10.5 or higher may damage the vinyl surface integrity over an extended period of time.
  - Disinfecting Wipes
    - Clorox, Green Works, PDI Sani-Cloth HB Wipes, Lysol, Oxivir, Virox, and CaviWipes.
  - For Tire cleaning, clean with off the shelf tire/wheel cleaners

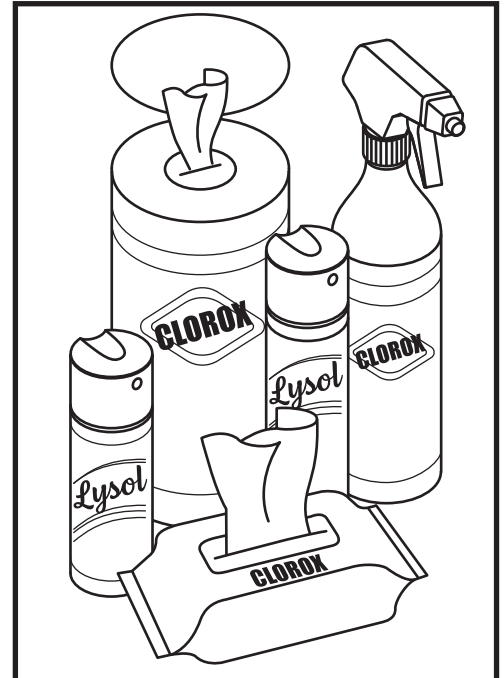

### Electronics

(Joystick controller, enhanced displays, touch screens, remote controls, keyboards, cell phones and tablets, as applicable)

- For electronics, remove visible contamination if present.
  - Turn off device and disconnect batteries.
  - Never spray any liquids directly into the product(s).
  - Moisten a microfiber cloth with a mixture of 70% isopropyl alcohol/30% water solution. The cloth should be damp, but not dripping or excessively wet. Dry surfaces thoroughly to avoid pooling of liquids and prior to boxing.

**WARNING! Follow all safety instructions for the proper use of the disinfectant and/or cleaning agent before applying it to your product. Failure to comply may result in skin irritation or premature deterioration of upholstery and/or power chair finishes.**

**WARNING! Never use any cleaning or disinfecting agent, solvent, lubricant, or any other product on the brake pads, brake discs, transaxle, motor/gearbox of your mobility product. Doing so may damage the components and/or cause them not to function properly. Property injury and/or personal injury may result.**



**WARNING! Never hose off your power chair or place it in direct contact with water. Your power chair has a painted, ABS plastic body shroud that allows it to be easily wiped clean with a damp cloth.**

**WARNING! Never use any chemicals to clean a vinyl seat, as they may cause the seat to become slippery or dry out and crack. Use soapy water and dry the seat thoroughly.**

# VII. CARE AND MAINTENANCE

## Wheel Replacement

If you have pneumatic tires and you have a flat tire, replace the tube. If your chair is equipped with a solid tire insert, then you must replace the whole wheel assembly. Replacement tires, tubes, and wheel assemblies are readily available through your authorized Pride Provider.

**WARNING! The wheels on your power chair should only be serviced or replaced by an authorized Pride Provider or a qualified technician.**



**WARNING! Be sure that the power to the controller is turned off and the power chair is not in freewheel mode before performing this procedure.**

**WARNING! When changing a tire, remove only the center lug nut and washer, then remove the wheel. If any further disassembly is required, deflate the tire completely or it may explode.**

Follow these easy steps for a quick and safe repair for both pneumatic and solid tires:

1. Turn off the power to the controller.
2. Make sure that the power chair is in drive mode. **See figure 4.**
3. Raise and support the power base so that the wheel is at least 1 in. (2.5 cm) off of the ground.
4. If you are changing a pneumatic tire, completely deflate it before removing the wheel.
5. Remove the hub cap, if equipped.
6. Remove the drive wheel nut and washer from the axle. **See figure 16.**
7. Remove the drive wheel from the axle. Make sure that you keep the key.
8. Remove the acorn nuts that fasten the two rim halves together.
9. Remove the old tube from the pneumatic tire and replace it with a new tube or replace the entire assembly if it is a solid tire.
10. Reassemble the two rim halves.
11. Slide the wheel back onto the axle. Make sure that the key is in the axle slot.

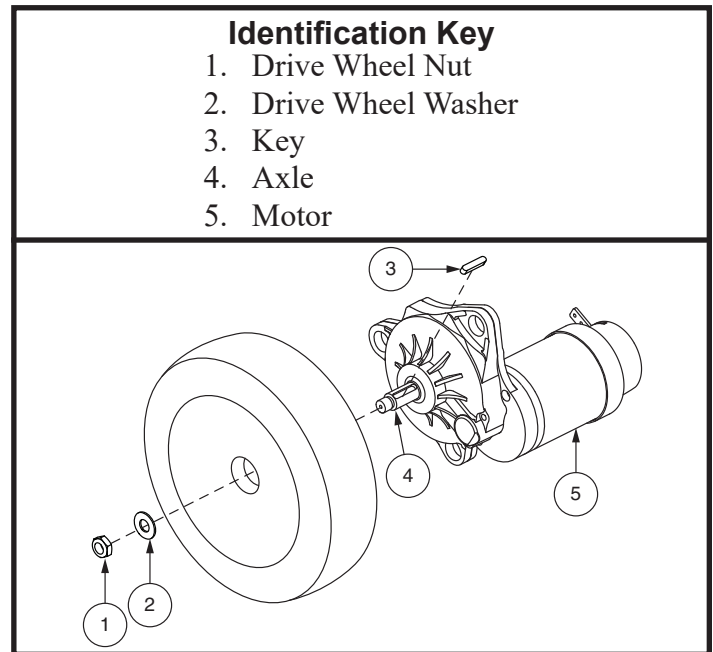

Figure 16. Drive Wheel Removal



**WARNING! Ensure that the axle key is properly installed into the axle slot when mounting the wheel. If not installed securely, the braking system is disengaged which may cause personal injury and/or product damage may result.**

12. Using a new drive wheel nut, reinstall the drive wheel nut and washer onto the axle and tighten. **See figure 16.**



**WARNING! Make sure both the nut and washer are reinstalled and tightened properly.**

13. Reinstall the hub cap, if equipped.
14. Inflate the pneumatic tire to the psi/bar/kPa air pressure rating indicated on each tire.
15. Remove the power chair from the base support.

# VII. CARE AND MAINTENANCE

## Battery Replacement

A battery wiring diagram is printed on a decal located on the power base. See VI. “Batteries and Charging” for correct battery specifications.



**MANDATORY!** Battery posts, terminals, and related accessories contain lead and lead compounds. Wear goggles and gloves when handling batteries and wash hands after handling.

**WARNING!** The batteries in your power chair should only be serviced or replaced by an authorized Pride Provider or a qualified technician.

**WARNING!** Do not replace batteries when seat is occupied.



**WARNING!** Power chair batteries are heavy. See specifications table. If you are unable to lift that much weight, be sure to get help. Use proper lifting techniques and avoid lifting beyond your capacity.

**WARNING!** Do not mix old and new batteries. Always replace both batteries at the same time.



**PROHIBITED!** Keep tools and other metal objects away from the battery terminals. Contact with tools can cause electrical shock.

You may need the following to replace your batteries:

- metric/standard socket set and ratchet
- adjustable wrench

To replace the batteries:

1. Turn off power to the controller.
2. Make sure that the power chair is in drive mode. See figure 4.
3. Loosen the thumbscrews at the rear of the power base and remove the rear shroud.
4. Loosen the thumbscrews on the sides of the power base and remove the side covers. See figure 17.
5. Disconnect the battery harnesses from the power base. See figure 17.
6. Loosen the tie-down straps, and slide the batteries out of the power base.
7. Remove the battery harnesses from the old batteries and install them onto the new batteries. Make sure that the hardware is facing the correct direction. See figure 17.



**WARNING!** Make sure you tighten the fasteners so that the connections are secure.

8. Place the batteries into the power base. Make sure that the terminals are facing the sides of the power base. See figure 17.
9. Connect the battery harnesses to the power base, and tighten the tie-down straps.
10. Reinstall the side covers.
11. Reinstall the rear shroud.
12. Charge the batteries. See VI. “Batteries and Charging.”

# VII. CARE AND MAINTENANCE

## Identification Key

1. Yellow Thumbscrews
2. Side Covers
3. Batteries

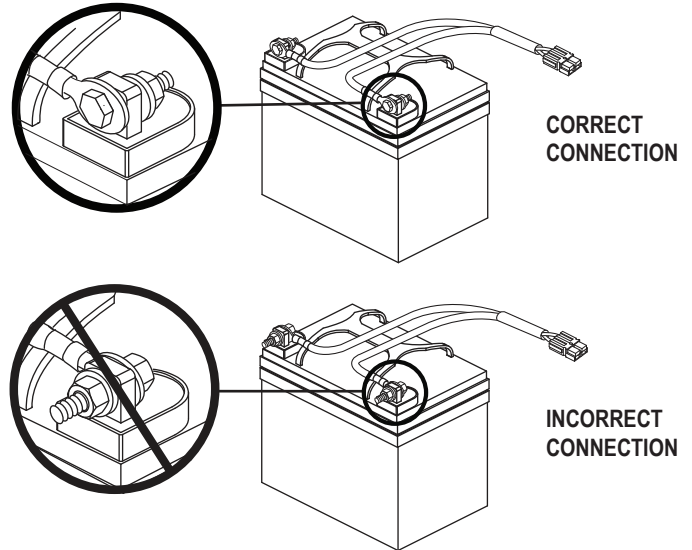
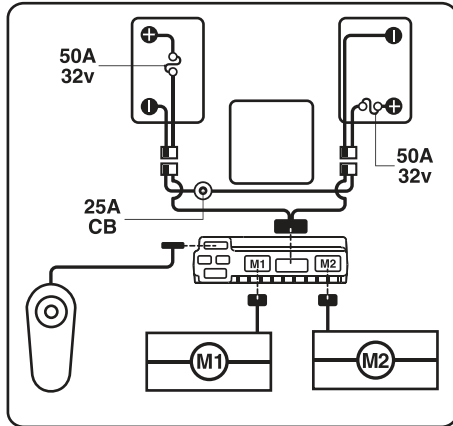

**Battery Set Configuration:**  
**+ = Positive (Red) Terminal Post**  
**- = Negative (Black) Terminal Post**  
**Connect Red wire to Red Positive (+) Terminal Post.**  
**Connect Black wire to Black Negative (-) Terminal Post.**

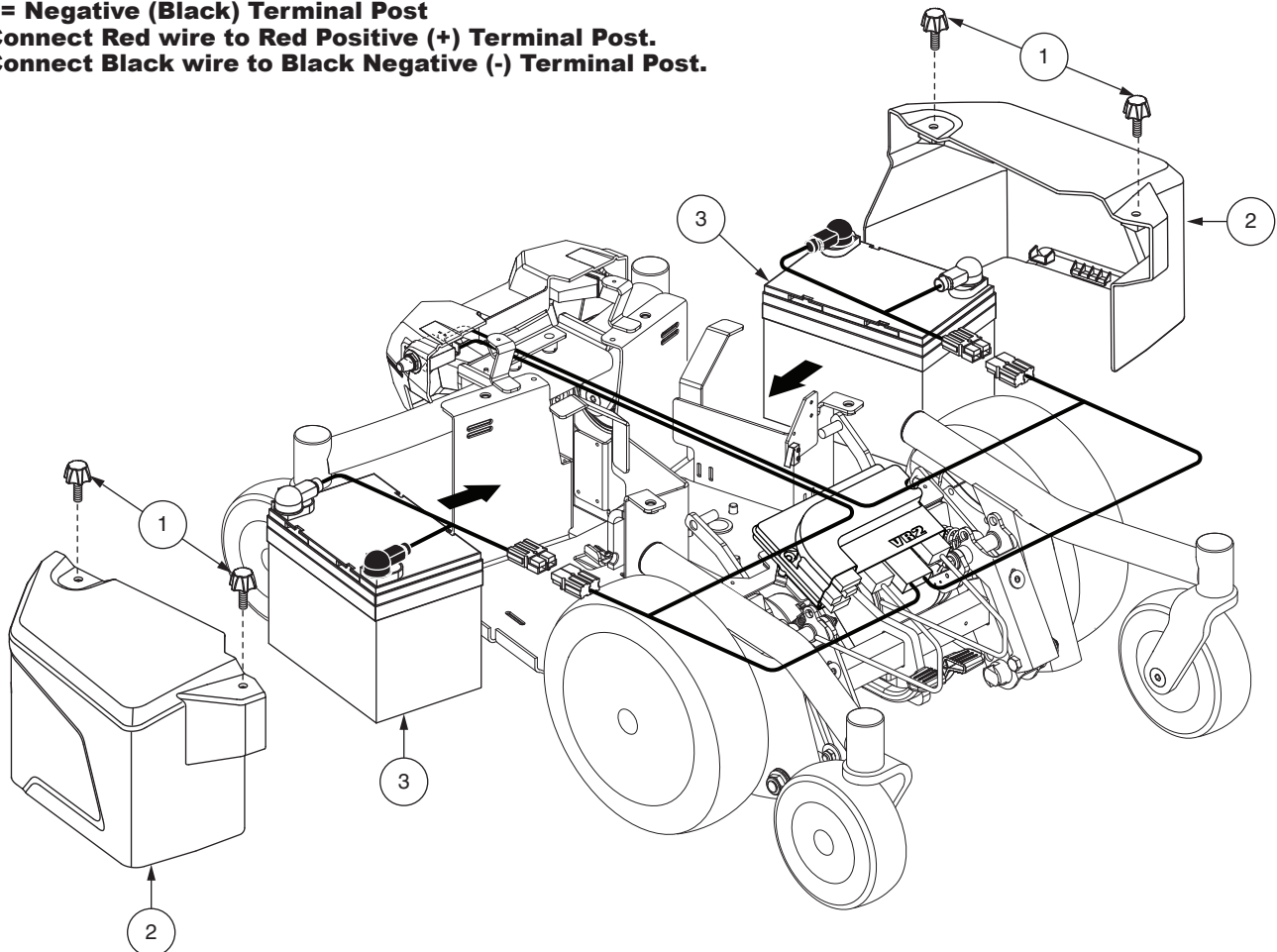

Figure 17. Battery Installation (Seat Removed for Clarity)

# VII. CARE AND MAINTENANCE

## When to See Your Authorized Pride Provider for Service

The following symptoms could indicate a serious problem with your power chair. If necessary, contact your authorized Pride Provider. When calling, have the model number, serial number, nature of the problem, and the error code if available.

- Motor noise
- Frayed harnesses
- Cracked or broken connectors
- Uneven wear on any of the tires
- Jerky motion
- Pulling to one side
- Bent or broken wheel assemblies
- Does not power up
- Powers up, but does not move
- Loose seat or seating components

## Corrective Maintenance

If the battery condition meter does not light up when you turn on the power:

- Check the harness connections. Make sure they are tight.
- Check the circuit breaker. Reset it if necessary.
- Check the battery connections.



# NOTES

# NOTES

# NOTES

## **USA**

401 York Avenue  
Duryea, PA 18642  
[www.pridemobility.com](http://www.pridemobility.com)

## **Canada**

5096 South Service Road  
Beamsville, Ontario L3J 1V4  
[www.pridemobility.ca](http://www.pridemobility.ca)

## **Australia**

20-24 Apollo Drive  
Hallam, Victoria 3803  
[www.pridemobility.com.au](http://www.pridemobility.com.au)

## **New Zealand**

3-5/208 Swanson Road  
Henderson, Auckland 0610  
[www.pridemobility.co.nz](http://www.pridemobility.co.nz)

## **UK**

(Authorised UK Representative)  
32 Wedgwood Road  
Bicester, Oxfordshire OX26 4UL  
[www.pride-mobility.co.uk](http://www.pride-mobility.co.uk)

## **The Netherlands**

(Authorised EU Representative)  
De Zwaan 3  
1601 MS Enkhuizen  
[www.pride-mobility.nl](http://www.pride-mobility.nl)  
[www.pridemobility.eu](http://www.pridemobility.eu)

## **Switzerland**

(Authorised CH Representative)  
SODIMED SA  
Chemin Praz Devant 12  
1032 Romanel-sur-Lausanne

## **Italy**

Via del Progresso-ang. Via del Lavoro  
Loc. Prato della Corte  
00065 Fiano Romano (RM)  
[www.pride-italia.it](http://www.pride-italia.it)

## **France**

26 Rue Monseigneur Ancel  
69800 Saint-Priest  
[www.pridemobility.fr](http://www.pridemobility.fr)

## **Spain**

Calle Las Minas Número 67  
Polígono Industrial Urtinsa II, de Alcorcón  
28923 Madrid  
[www.pridemobility.es](http://www.pridemobility.es)

## **Germany**

Hövelrieger Str. 28  
33161 Hövelhof  
[www.pridemobility.de](http://www.pridemobility.de)

## **China**

Room 508, Building #4, TianNa Business Zone  
No. 500 Jianyun Road, Pudong New Area  
Shanghai 201318  
[www.pridechina.cn](http://www.pridechina.cn)

---

Product Serial #

\* I N F M A N U 4 9 2 2 \*

UDI Label (if applicable)

